

Cambio de diseño de balatas CARTEK C7177-D227.

ANTES

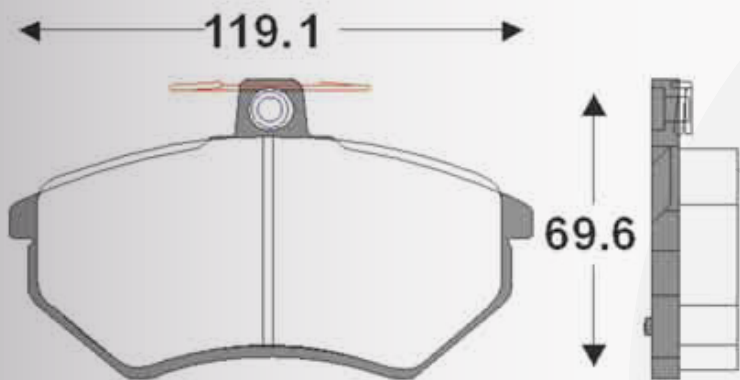

DESPUES

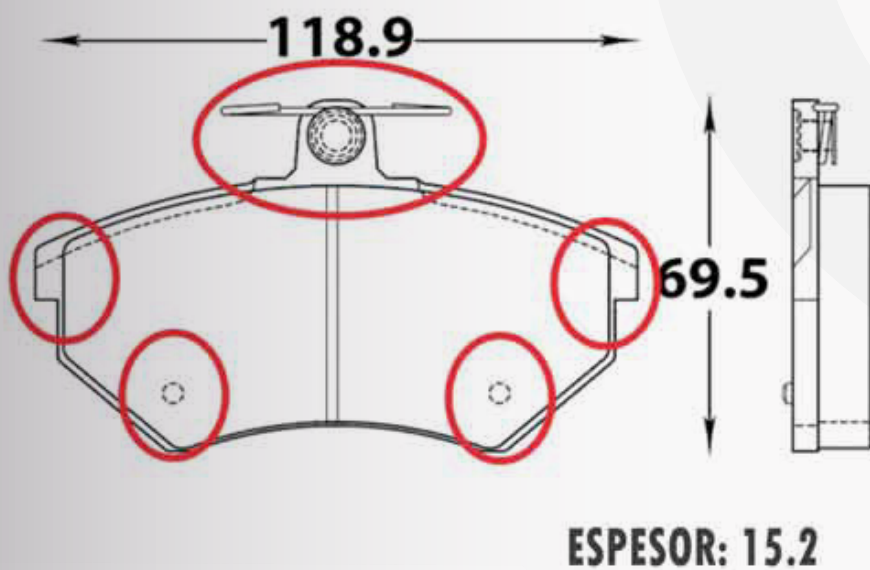

BALATAS SEMIMETÁLICAS

SIN ASBESTO
SIN PLOMO



REFERENCIA	POSICIÓN	MARCA	APLICACIÓN	ESPESOR
7177-D227	DELANTERA	AUDI	4000S TURBO QUATTRO	15.2
7177-D227	DELANTERA	AUDI	4000S QUATTRO 84 - 86	15.2
7177-D227	DELANTERA	AUDI	COUPE GT 85 - 87	15.2
7177-D227	DELANTERA	AUDI	90 84-97	15.2
7177-D227	DELANTERA	AUDI	80 87-90,	15.2
7177-D227	DELANTERA	VOLKSWAGEN	80 87 - 90	15.2
7177-D227	DELANTERA	VOLKSWAGEN	90 84 - 87	15.2
7177-D227	DELANTERA	VOLKSWAGEN	DERBY ROTOR VENT 99-05	15.2
7177-D227	DELANTERA	VOLKSWAGEN	GOLF 84 - 91 / 95 - 98,	15.2
7177-D227	DELANTERA	VOLKSWAGEN	GOLF GTI 92-99	15.2
7177-D227	DELANTERA	VOLKSWAGEN	GOLF GLS 93-98	15.2
7177-D227	DELANTERA	VOLKSWAGEN	GOLF VR6 96	15.2
7177-D227	DELANTERA	VOLKSWAGEN	JETTA 87-97	15.2
7177-D227	DELANTERA	VOLKSWAGEN	JETTA CARAT 95-93	15.2
7177-D227	DELANTERA	VOLKSWAGEN	JETTA CL, GL, GLS 96-99	15.2
7177-D227	DELANTERA	VOLKSWAGEN	JETTA GLI 90 - 94	15.2
7177-D227	DELANTERA	VOLKSWAGEN	JETTA GLS 93-94	15.2
7177-D227	DELANTERA	VOLKSWAGEN	JETTA GLX 97-98	15.2
7177-D227	DELANTERA	VOLKSWAGEN	JETTA VR6 95	15.2
7177-D227	DELANTERA	VOLKSWAGEN	PASSAT 84 - 97	15.2
7177-D227	DELANTERA	VOLKSWAGEN	PASSAT WAGON 92	15.2
7177-D227	DELANTERA	VOLKSWAGEN	PASSAT VR6 96-04	15.2
7177-D227	DELANTERA	VOLKSWAGEN	QUANTUM 86 - 88	15.2
7177-D227	DELANTERA	VOLKSWAGEN	SIROCCO 16 VALVE 88 - 89	15.2

Observaciones:

Los cambios en la zapata no afecta la instalación ni desempeño en ninguna de las aplicaciones asignadas.